



Walker Engineering Enterprises

9255 SAN FERNANDO ROAD SUN VALLEY CA, 91352 (818) 252-7788 FAX (818) 252-7785

ALGAESEP®

Dynamic Fuel / Water Separator™

OWNERS MANUAL

All Models

- FOR USE WITH DIESEL FUEL ONLY -

- SAFETY IS IMPORTANT -

The Walker AlgaeSep® is built and designed with safety at the forefront. Your overall safety can be increased by proper installation and thoughtful operation of the system.

**DO NOT INSTALL, OPERATE, OR REPAIR THIS EQUIPMENT WITHOUT
READING THIS MANUAL AND SAFETY PRECAUTIONS INDICATED
THROUGHOUT THE MANUAL.**

This system involves the handling of volatile fuel, please think before you act, be responsible, and be careful.

If you have any questions regarding the installation of the system or its components please contact Walker Engineering before proceeding.



RECOMMENDATION

Installation, maintenance or repair procedures should be performed by qualified individuals with basic experience working with marine fuel systems.

We recommend the system be installed at a boatyard, boat dealer, or other similar marine service facility.

Walker Engineering



Introduction to the Walker Engineering AlgaeSep®

Thank you for choosing the latest product to join the Walker Engineering line, the **AlgaeSep**, the only dynamic fuel / water separator designed specifically for use on pleasure craft and commercial vessels as well as industrial applications.

AlgaeSep polishes the fuel, removing water and algae directly from the source, your fuel tank. The effectiveness of the system is clearly visible in the sight glass. The system can operate on vessels anytime both underway or at the dock. Even when underway the system will draw fuel from the tanks, and continue to remove water and debris, further reducing the total amount of contaminants in the fuel.

AlgaeSep prevents excessive clogging of costly fuel / water filters, extending their service life, reducing maintenance time, and preventing unexpected fuel related engine shutdowns. With regular use of the **AlgaeSep** the total amount of water and debris in the fuel tank will be greatly reduced. The absence of water will prevent new Algae from growing.

Walker Engineering, manufacturers of the **AirSep**, closed crankcase system are world renowned in the diesel engine industry as an ISO9001 Quality Registered Manufacturer, the products we bring to market are very reliable for assured performance in the most demanding environment.

This manual contains important information for the installation and operation of your **AlgaeSep®**, keep this manual handy and review it periodically.

When modifying the fuel system we recommend professional installation by a qualified mechanic or boat yard that is familiar with all applicable standards for fuel systems with your type of vessel or application.

If you have additional questions, please call (818) 252-7788, Walker Engineering Enterprises, Inc.



SAFETY PRECAUTIONS

Failure to follow this warning could result in property damage, serious injury, or death.

WARNING !! - This system can ONLY BE USED ON DIESEL ENGINE FUEL SYSTEMS.

Be sure that all installation, maintenance, operation, and repair procedures are performed by qualified individuals, trained and experienced in installing and repairing diesel engine fuel systems.

NOTE: It is very important to ensure any new fittings or other attachments to the fuel tanks, fuel system or mounting areas are compatible with the existing materials.

Walker Engineering Enterprises/Walker Design Inc. does NOT APPROVE the use of the AlgaeSep® Dynamic Fuel/Water Separator™ on gasoline fuel systems, as fire or explosion may occur.

DO NOT use in unventilated areas.
DO NOT use near open flames.
DO NOT use near exposed electrical wires.
DO NOT drain separator into bilge area.
DO NOT disassemble separator.
DO NOT install near engine exhaust system.
DO NOT operate separator unattended.

VERIFY vessel voltage requirement, 12 or 24. ONLY USE AlgaeSep marked with the appropriate voltage.

CHECK fuel lines and fittings regularly for cracks or leaks. Replace when required.

DRAIN separated water into a Coast Guard approved container for later disposal according to state, local and federal regulations.

INSTALLATION STEPS

MATERIAL SELECTION

System Component Selection: It is suggested the new fuel pickup consist of stainless steel tube with a flexible piece of appropriate hose at the end to rest at the very bottom of the tank.

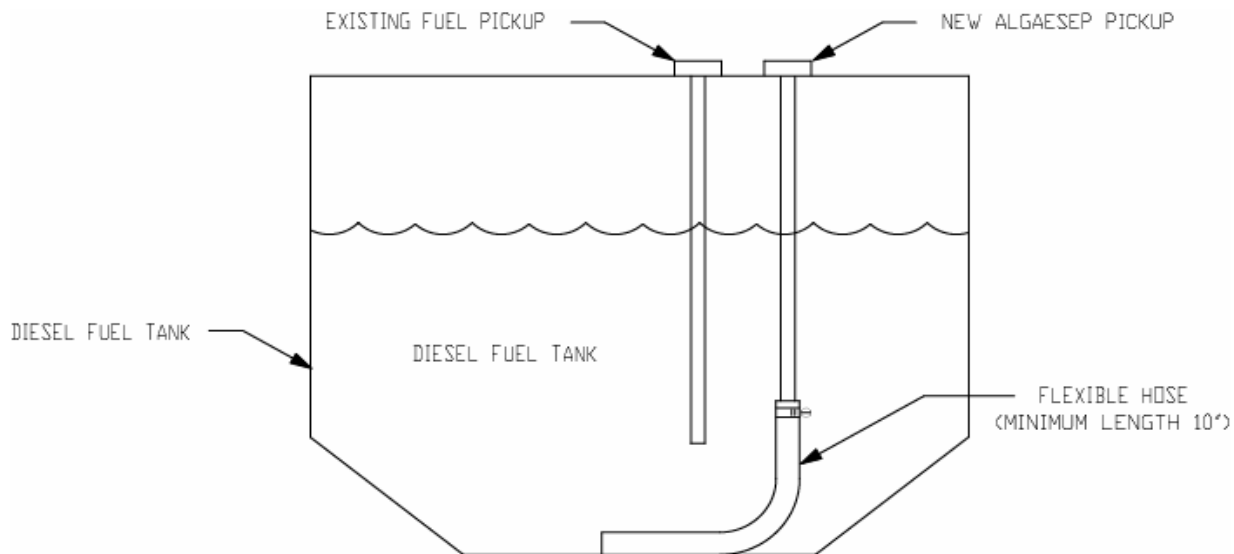

NOTE: It is very important to ensure any new fittings or other attachments to the fuel tanks, fuel system or mounting areas are compatible with the existing materials.



INSTALLATION STEPS

A) Fasten the separator securely to a bulkhead or other structurally sound member at a safe location where the separator bottom drain valve can be easily accessed with adequate clearance height to permit draining into a 2 gallon Coast Guard approved fuel container.

(See Drawing for mounting detail).

B) After mounting the AlgaeSep securely to the bulkhead, install a 3/8" ID, Coast Guard approved fuel line from the fitting marked RETURN on the separator to a return line fitting on the fuel tank. **(See Drawings for single tank installation or multi-tank installation).**

[TIP: Installers often choose to use 90° fittings at the unit to allow the fuel lines to run smoothly to a bulkhead or support member.]

C) Install a fuel pick-up tube or hose at the lowest point in the fuel tank and connect to a 3/8" ID, Coast Guard approved fuel line that will connect to the fitting on the separator marked INTAKE / SUCTION.

(See Material Selection on the following page).

If more than one tank is being used, it will be necessary to install a selector valve in the fuel lines so that the fuel in each tank may be processed.

WARNING !! Before connecting power to the AlgaeSep panel, verify the unit is marked with the voltage appropriate for your vessel or application. **(12V and 24V models are available).**

D) 1) Remove the cover on the electrical box and identify terminals number 2 and 3, there should be a sticker below them identifying the positive and negative terminals.

2) Attach suitable marine grade wire to connect power to the positive terminal (#3) and ground to terminal (#2).

3) Replace electrical box cover and secure with the four screws provided. **(See Drawing for electrical box layout.)**



INSTALLATION STEPS

- Continued -

TEST RUN

E) CAUTION !! Before turning power on, Verify the control box cover is in place and properly secured. Check and close the vent valve and drain valve.

To start the Walker ALGAE-SEP® turn the system power switch to on. The diesel fuel recirculating pump will self prime and start pulling fluid from the fuel storage tank through the separator.

[A chatter sound is normal until the self priming pump removes air from the system.]

WARNING !! Check for leaks at all factory fittings and all installed fittings and hoses, if leaks are detected, turn the unit off immediately and make necessary adjustments.

RE-TEST

CAUTION !! If any adjustments are made, re-run initial test procedure (E) above.

F) Initial operation run, the system should run 1 to 3 hours. During this initial run the system should be inspected periodically for leaks or excess vibration. If the high water alert light comes on during the initial operation of the AlgaeSep it is recommended that you stop the pump and drain the water from the unit then proceed.

- OPERATION SAFETY -

- Do NOT enter a confined or unventilated space to service separator.
- No smoking or use of open flame while servicing separator.
- Use an approved fuel container to store fuel contaminants drained from separator until disposal.
- Do NOT operate separator unattended for long periods of time.
- Check fuel lines and fittings for cracks and leaks frequently.



Normal Operation

After passing the initial operational test the AlgaeSep is ready for normal operation.

To start the AlgaeSep® turn the system power switch to the on position. The diesel fuel recirculating pump will self prime and start pulling fluid from the fuel storage tank through the separator.

The system can run until the high water alert light comes on or 4 hours has past. It is not recommended the system run for periods longer than 4 hours without being inspected or drained.

Water and contaminants must be drained from the separator
after each period of operation:

CAUTION !!

1) WITH THE UNIT OFF - Open the air inlet valve located at the top of the separator, and then open the water drain valve located at the bottom of the separator.

It is recommended the debris filter be replaced at 250 hours after processing normal algae growth levels in the fuel supply. Service with fuel filter element part number; 100-1052.

NOTE; The water and contaminates should be drained into an appropriate waste container. The residual water is easily recognized, and may contain microbial contaminants such as algae, fungi, bacteria, mold and slime all of which is removed from the fuel supply by the AlgaeSep and drained from the separator into the waste container.



Special Operation

- FUEL TANK TREATMENT -

If your fuel or storage tank has had an ALGAE BLOOM problem it is suggested to "shock" the fuel to kill the excess algae and allow the AlgaeSep® to remove the dead organisms.

It is recommended that all effected fuel tanks, be treated with a Fuel Biocide such as, " BIOBOR" or " VALVETECT BIOGUARD" to kill any live micro organisms that may be present in the fuel supply.

Apply the treatment and wait at least 3 hours. Start the AlgaeSep® and operate for a period of at least 2 hours to remove dead microbes along with any free water that may be in the tank.

For problem tanks with widespread growth, it may be necessary to repeat the Biocide treatment, and continue to process fuel in 3 hour intervals until the fuel shows a definite improvement in clarity.

It is not recommended the system run for periods longer then 4 hours without being drained.

Be sure to drain the water and microbes if the high water alert light comes on before the end of the cycle as described above in the normal operation section.

It is recommended the debris filter be replaced at 100 hours after processing abnormal algae growth problems. Service with Walker fuel filter element part number, 100-1052.



Maintenance

- ROUTINE MAINTENANCE -

The AlgaeSep has been designed to require a minimum of routine service and maintenance.

Every 100 hours or twice a year.

Check fuel lines and fittings for cracks and leaks. Replace as necessary.

Every 250 hours or once a year.

Replace "Spin-On Debris Filter" **every 250 hours** of operation or sooner if large quantities of contaminants are observed in the drain container. Service with fuel filter element part number, 100-1052.

Replacement Parts.

The AlgaeSep is designed for years of trouble free operation. However in the unlikely event you require replacement parts, please visit the Walker Website at www.walkerairsep.com. Be sure to fill out the "Contact Us" form with your request for availability and pricing of the specific parts needed.

Fuel Pump.

The AlgaeSep circulating pump has been proven for long life and reliable operation. A 5 amp circuit breaker protects the unit from voltage overload. In the unlikely event a replacement pump is required, please be sure to specify the system voltage when ordering.

AlgaeSep fuel / water separator unit.

The AlgaeSep does not need service if operated properly and should not be disassembled under normal circumstances.

There are no user serviceable parts inside the separator canister.

The fuel that is pumped through the unit not only acts as a lubricant but also continuously flushes dirt and debris out of the system to be drained away.



Troubleshooting

- Problem -	- Probable Cause -	- Suggested Solution -
No indicators light when system power is turned on.	Power Interruption.	<p>Check the circuit breaker on the AlgaeSep.</p> <p>Check the power source.</p>
Pump vibrates and is noisy.	Air is in the system.	This is normal until the pump primes itself, and eliminates the air in the system.
I don't see the unit processing fuel through the system.	Air is entering the system.	The pump may be pulling air due to loose fittings or cracked fuel lines.
Contaminants and Algae are still showing up in the drain container, even after several weeks of using the AlgaeSep®.	Widespread algae in fuel tanks.	<p>Your fuel tank is contaminated with live fungi and bacteria.</p> <p>Treat your tank with diesel fuel biocide.</p> <p>After treatment, process the fuel with the AlgaeSep to purify fuel and remove dead microorganisms.</p> <p>Please consult your manual.</p>

AUTO-OFF SYSTEM

The Auto-Off feature allows you to start a processing cycle and have the AlgaeSep automatically shut off after about 4 hours.

To reactivate the system after the Auto-Off feature shuts the unit off, move the Power ON / OFF switch to the OFF position. When turned back ON, the system will reset and activate for another processing period of the same duration.

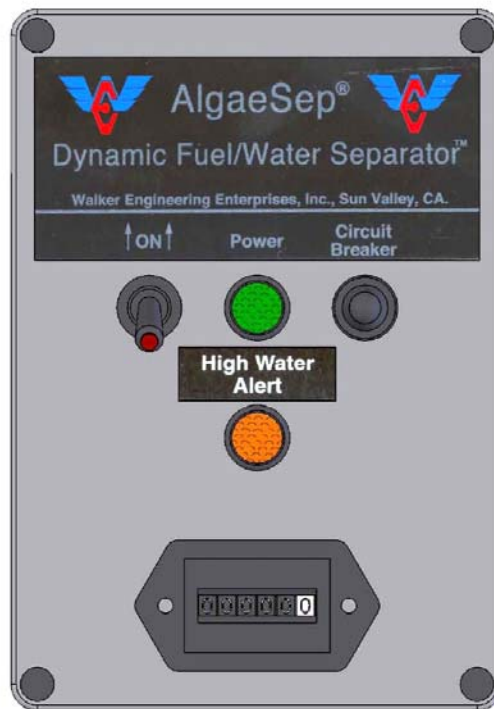

HIGH WATER WARNING LIGHT

When the amber warning light is lit, it signals that the amount of water removed from your fuel tank is approaching a level in the AlgaeSep where it must be drained. If the light stays on, you should drain the water from the unit as soon as possible. Draining the unit regularly is required to maintain maximum water separation efficiency during the processing cycle.

HOUR METER

The AlgaeSep is equipped with an hour meter to make it easy to keep track of running time and fuel filter change intervals.

The hour meter is automatically activated when the AlgaeSep is operating and never needs service.





AlgaeSep® SYSTEM SPECIFICATIONS ALL MODELS

Pump Capacity:	40 Gallons / Hour
Power:	24 volt (12 volt upon request)
Circuit Breaker:	5 Amps
Debris Filter:	Replace every 250 Hours with 25 micron element.
Filter Part Number:	- Walker Engineering P/N 100-1052 <i>If unavailable, substitute with;</i> - Wix P/N 24006 - Napa P/N 4006
Port Size:	- "Suction" 3/8" NPT - "Return" 3/8" NPT
Maximum Operating Vacuum:	10" Hg

AlgaeSep®

Reference Drawings

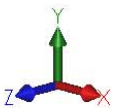

NOTES: UNLESS OTHERWISE SPECIFIED

1. ENVELOPE DRAWING, FOR REFERENCE ONLY.

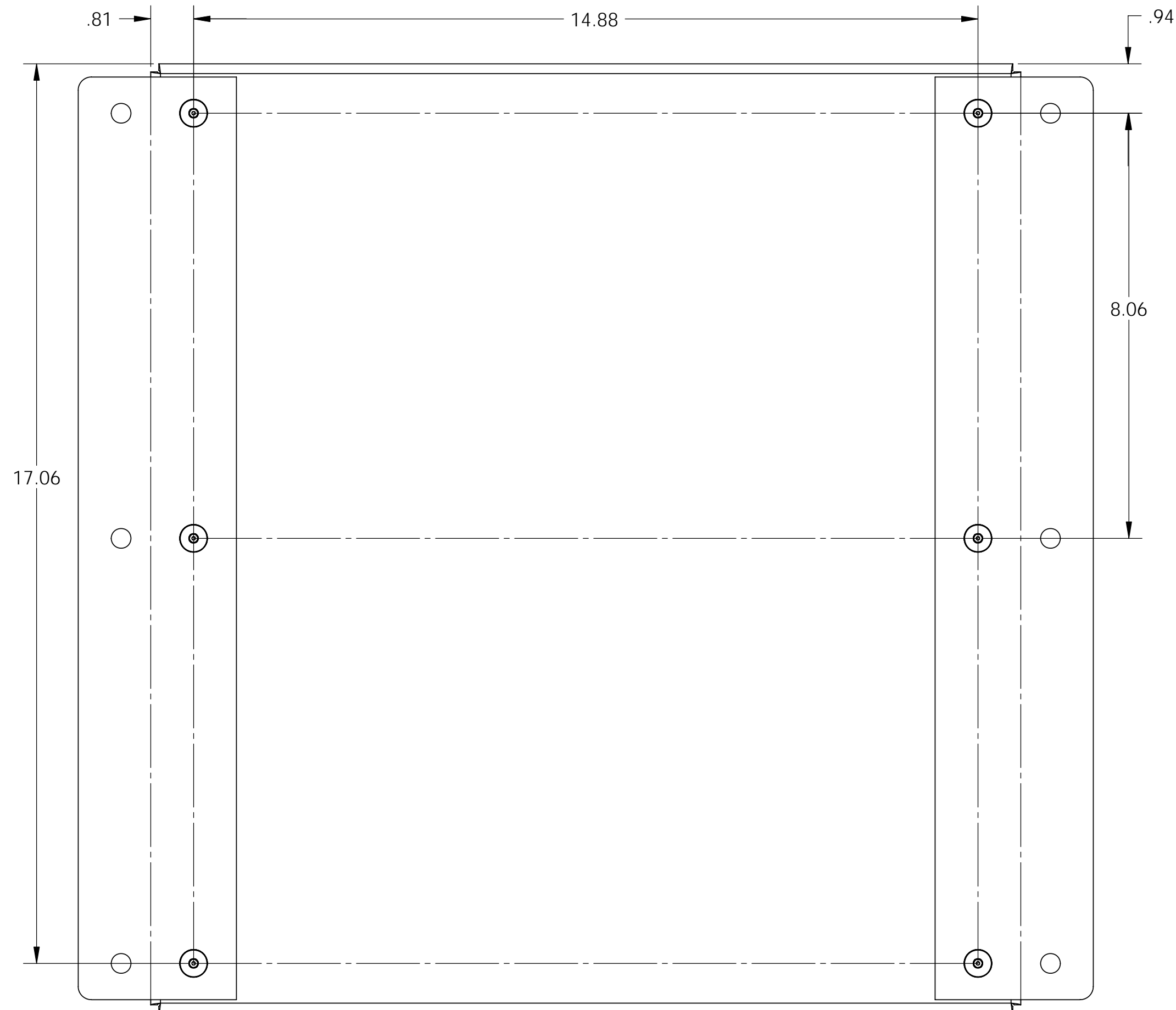

REAR VIEW

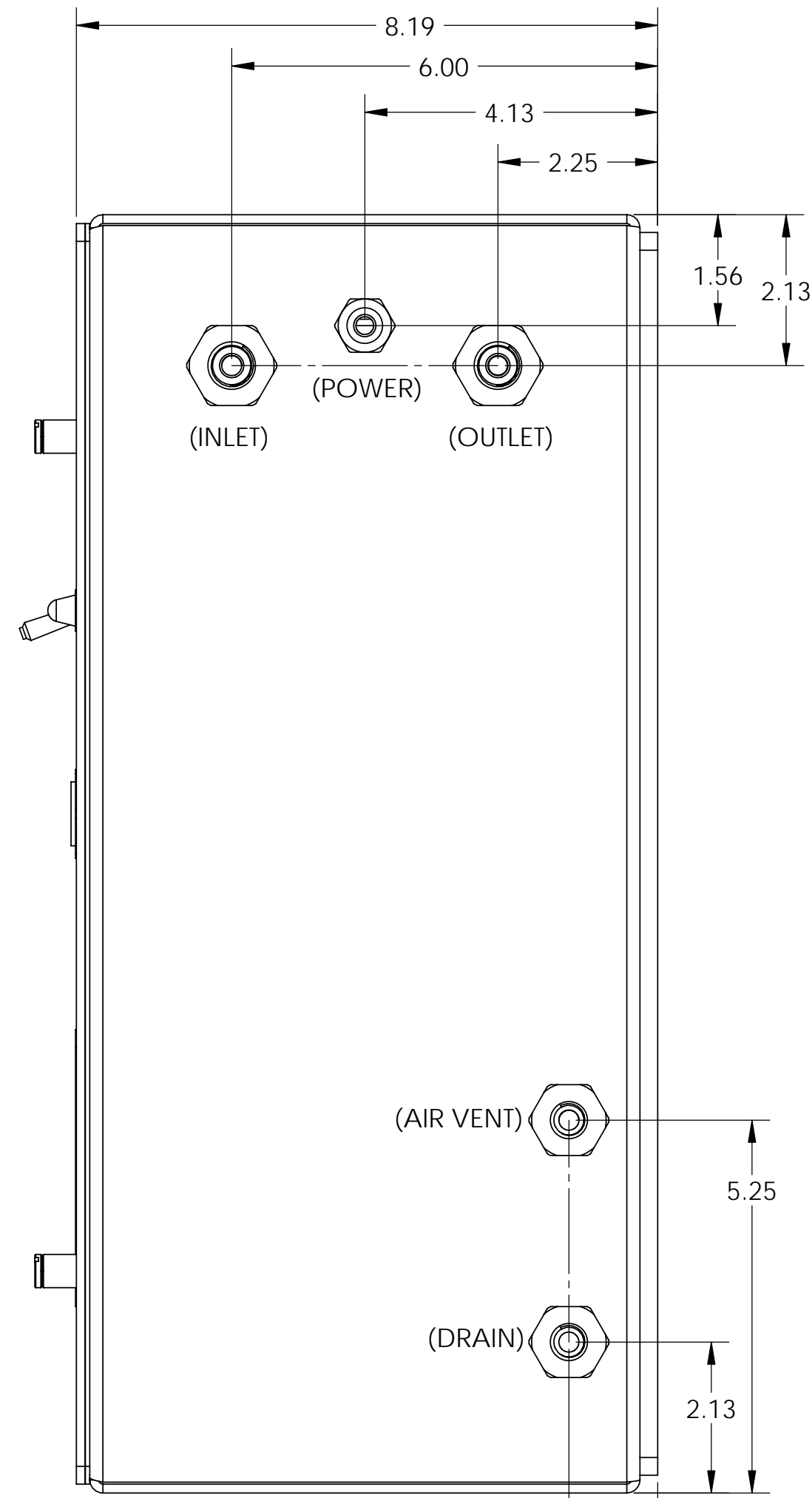

RIGHT VIEW

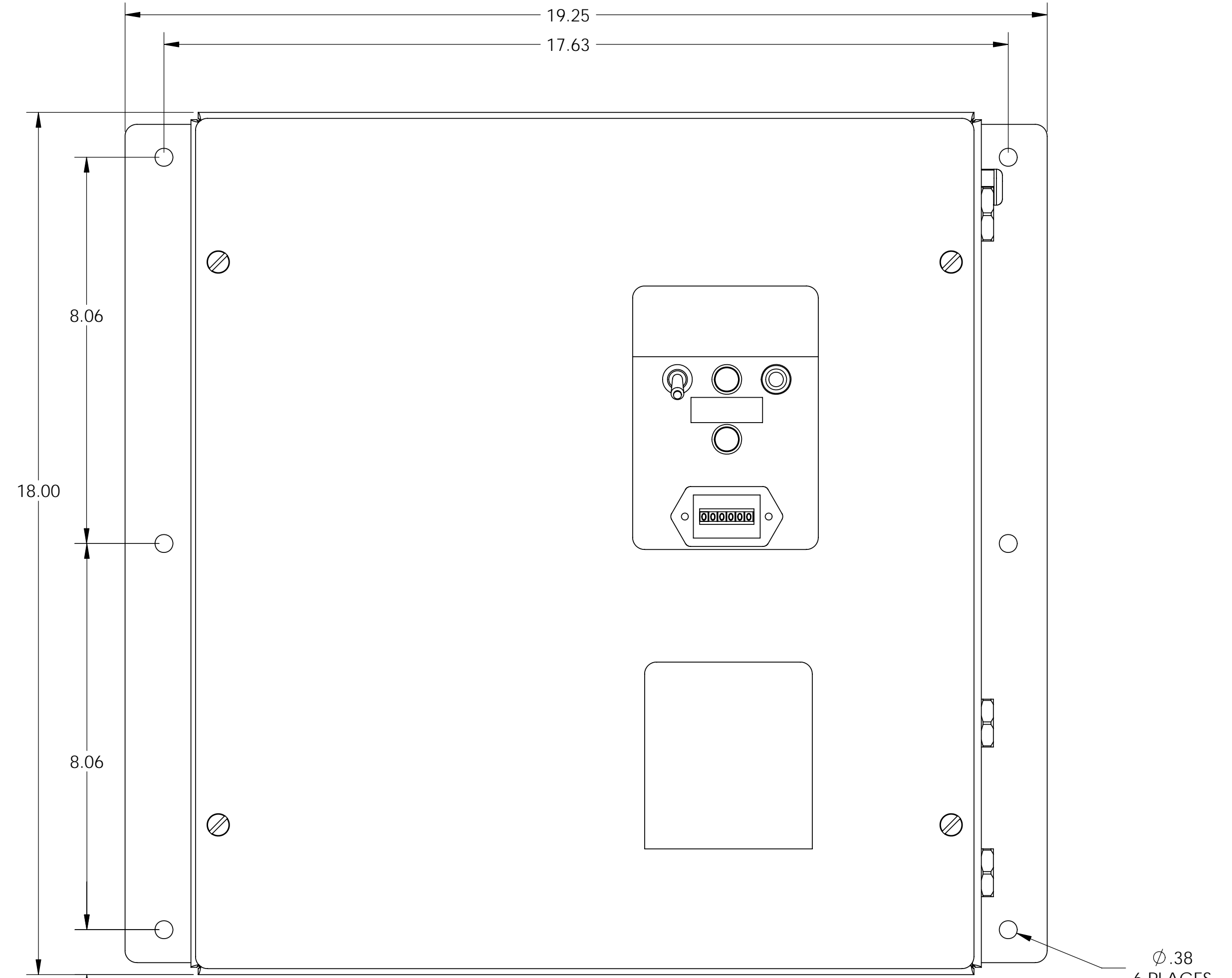

FRONT VIEW

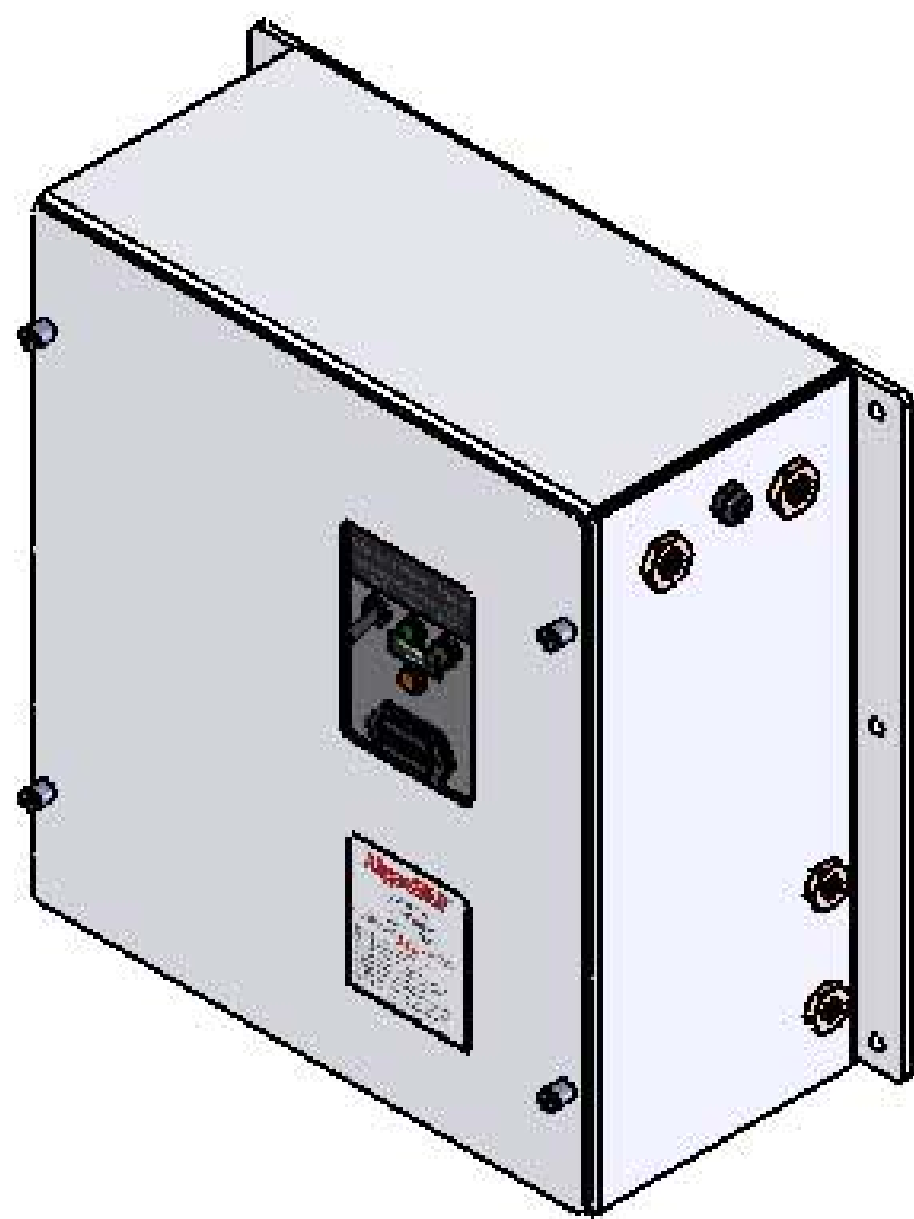

ISOMETRIC VIEW
SCALE 1:4

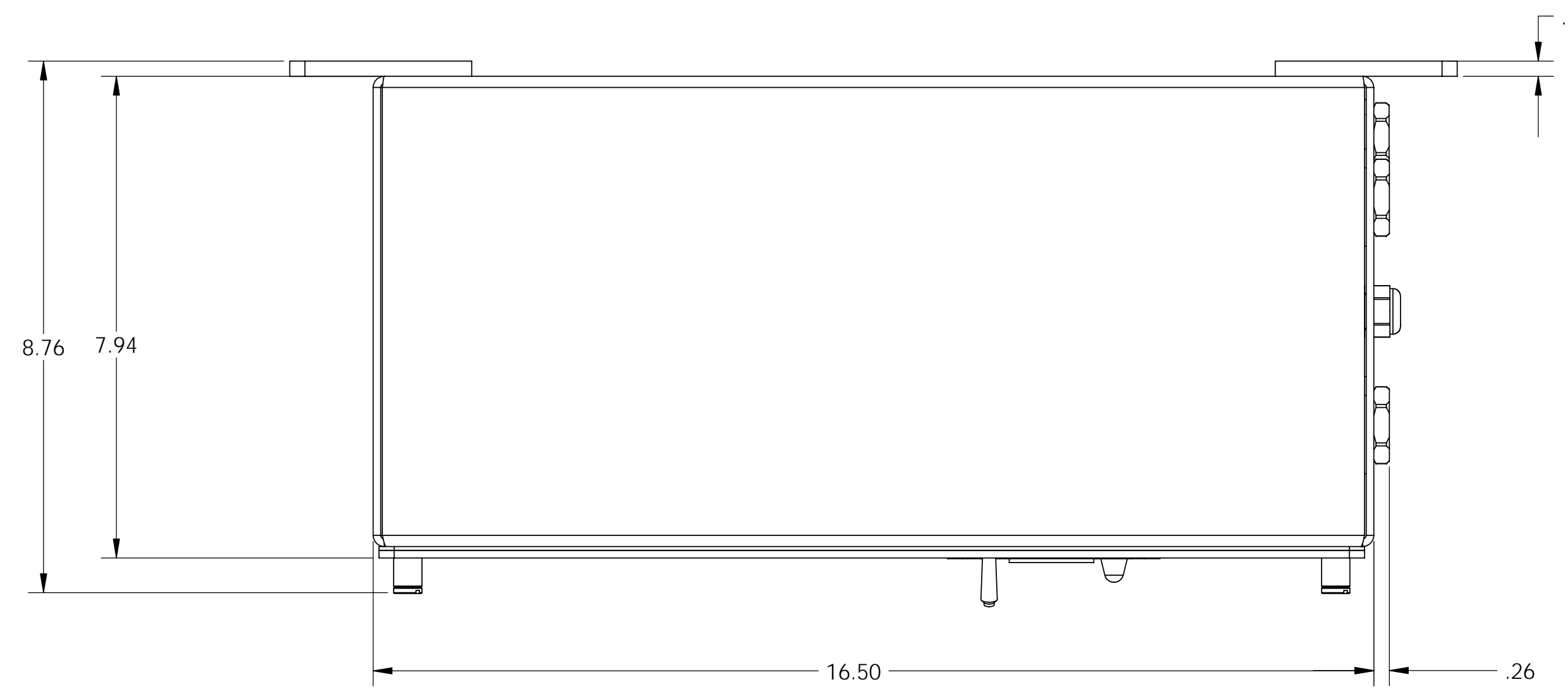

TOP VIEW

PROPRIETARY AND CONFIDENTIAL
THE INFORMATION HEREIN CONTAINS
PROPRIETARY RIGHTS OF
WALKER ENGINEERING ENTERPRISES
AND IS NOT TO BE REPRODUCED, USED,
OR DISCLOSED TO OTHERS FOR ANY
PURPOSE EXCEPT AS SPECIFICALLY
AUTHORIZED IN WRITING BY
WALKER ENGINEERING ENTERPRISES.

UNLESS OTHERWISE SPECIFIED:		NAME	DATE	 <small>Walker Engineering Enterprises 1000 S. Bascom Avenue, Suite 100, San Jose, CA 95128 Tel: 408.253.1100 Fax: 408.253.1101</small>
DIMENSIONS ARE IN INCHES		DRAWN	JW	
TOLERANCES:		ENG. APPR.		
FRACTIONAL ±		SALES & MARKETING		
ANGULAR ±1°		MFG APPR.		
TWO PLACE DECIMAL ±.03		QA		
THREE PLACE DECIMAL ±.010		PURCH.		
INTERPRET GEOMETRIC TOLERANCING PER: ASME Y14.5M				
MATERIAL				
FINISH				
NEXT ASSY	USED ON	 THIRD ANGLE PROJECTION		TITLE: ALGAESEP ENVELOPE DRAWING
APPLICATION		SCALE: 1:2	WEIGHT:	SIZE DWG. NO. D ALGAESEP ENV REV X1
		DO NOT SCALE DRAWING		SHEET 1 OF 1

DATE	REV.	DESCRIPTION
12-05-08		NEW DRAWING



INSIDE VIEW OF BOX LID

INSIDE VIEW OF BOX

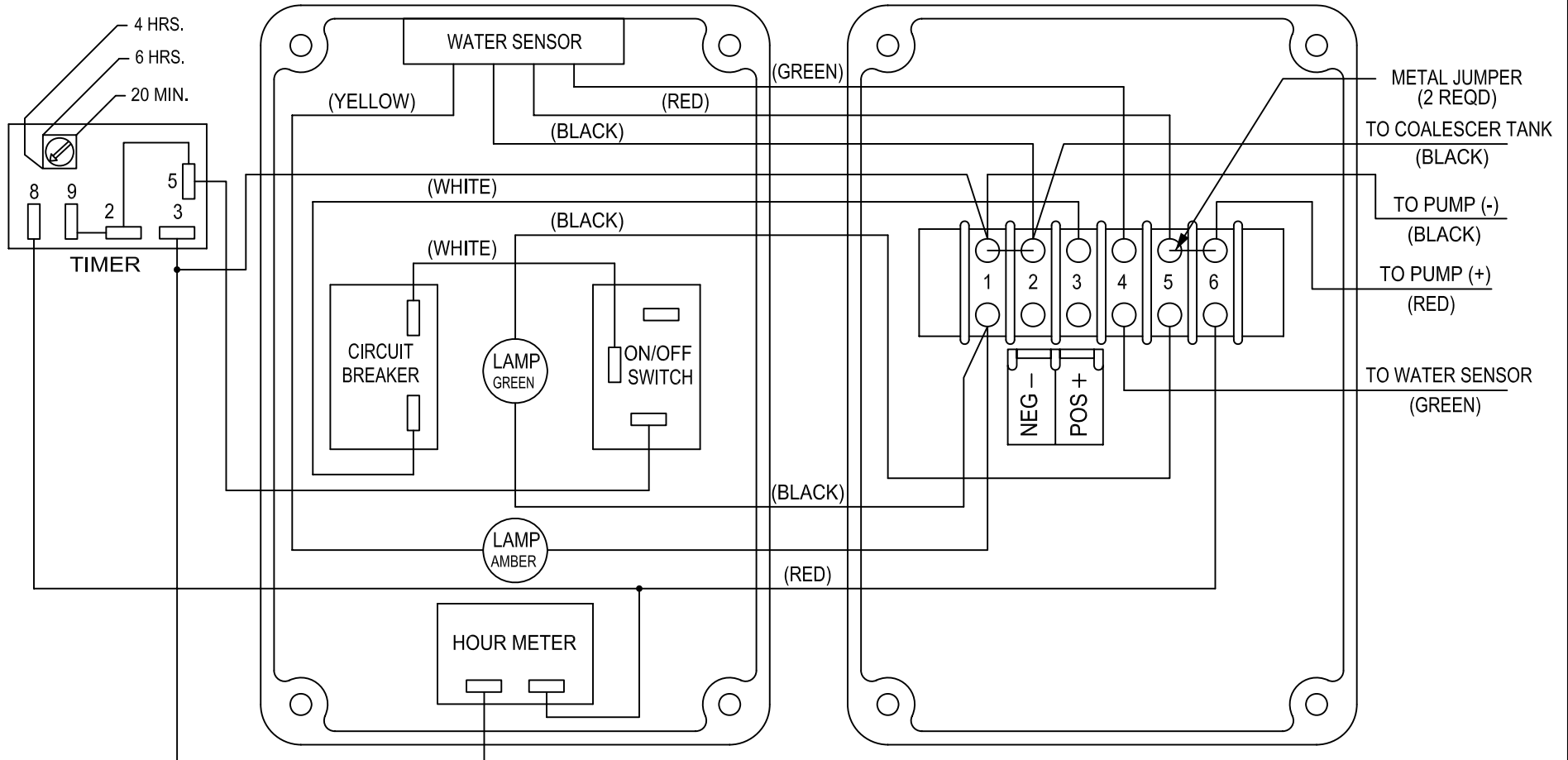

NOTE: FOR 12 OR 24 VOLT APPLICATIONS

WALKER ENGINEERING		
SCALE : NONE	ALGAESEP WIRING SCHEMATIC, WITH TIMER, WATER SENSOR, HOUR METER	TOLERANCE UNLESS OTHERWISE NOTED
DRAWN BY : MB		.X = ±
DATE : 12-05-08		.XX = ±
APPROVED BY :		.XXX = ±
REVISD :		DRAWING NO. : ACD2000
PART NUMBER :		
MATERIAL :		